

功率无刷电机

外形尺寸(参考) Outside Dimension (Reference)

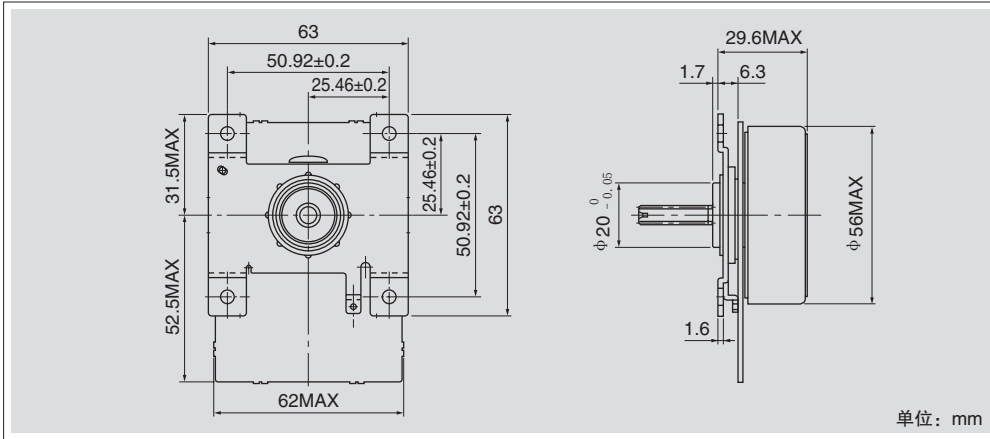

单位: mm

- 该产品是对应客户需求的定制产品, 详细规格及订货量请咨询本公司销售人员。
- Please contact our sales for detail specification & order lot QTY. (All custom product by customer's requirement)



- $\Phi 55 \times L30$ 外转子式直流无整流子电机
- DC Brushless motor outer rotor type

产品特点 Characteristic

- 电机方式 Motor Type
3相DC无刷电机
3 Phase DC Brushless Motor
- 旋转方向 Direction of Rotation
CW and CCW
- 内置驱动控制电路 Control-Driver circuit built-in.
- 小型、轻盈、高输出 Compact, Light Weight and High Output
- 高效率 High Efficiency
- 低噪音 Low Noise
- 过电流/限制保护 Overcurrent and Locked Rotor Protection
- 也可提供切齿输出轴型
The gear machined output, shaft type is available as an option.

典型特性 Major Characteristic Parameters

项目	最小 Min.	额定值 Nom.	最大 Max.	单位 Units
使用电压 Operating Voltage	21.6	24	26.4	VDC
使用转速 Operating Speed	600		3000	min ⁻¹
连续动作额定输出 Continuous Rating Power			40	W
转动惯量 (参考值) Rotor Inertia (Reference Value)		565		g · cm ²
工作温度范围 Operating Temperature	0	20	50	°C
工作湿度范围 Operating Humidity	15		90	%RH
重量 Motor Weight			270	g

